Applications of dual equivalence graphs

Sami Assaf

University of Pennsylvania

sassaf@math.mit.edu



MSRI

Mathematical Sciences
Research Institute

I. Graphs on tableaux

- Crystal graphs
- Dual equivalence graphs

II. Symmetric functions

- Schur positivity from graphs
- LLT and Macdonald polynomials

III. Representation Theory

- Weyl groups acting on 0 -weight spaces
- From crystal graphs to dual equivalence graphs

I. Graphs on Tableaux

Crystal graphs

In 1990, Kashiwara introduced crystal bases for representations of quantized universal enveloping algebras at $q = 0$.

A **crystal graph** is a directed, colored graph on the crystal basis with edges given by deformations of the Chevalley generators e_i and f_i .

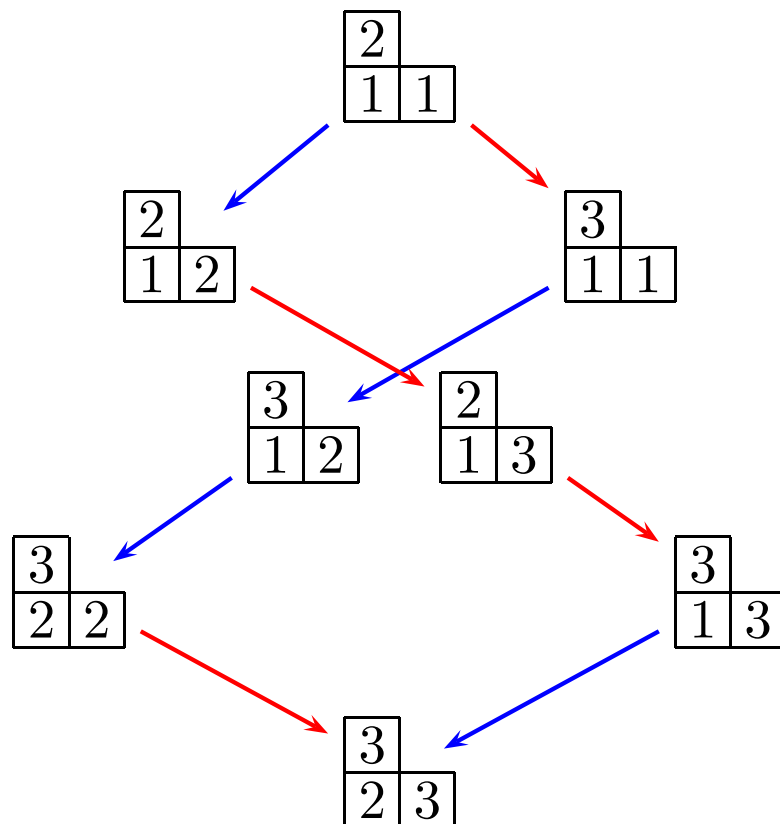

Let E_λ be the irreducible representation of $U_q(\mathfrak{sl}_n)$ with highest weight λ .

The crystal basis for E_λ is indexed by $\text{SSYT}(\lambda)$. Denote the **crystal graph** by \mathcal{X}_λ^n .

Littelmann and Kashiwara-Nakashima gave combinatorial descriptions of crystal graphs in terms of SSYT.

Examples of crystal graphs

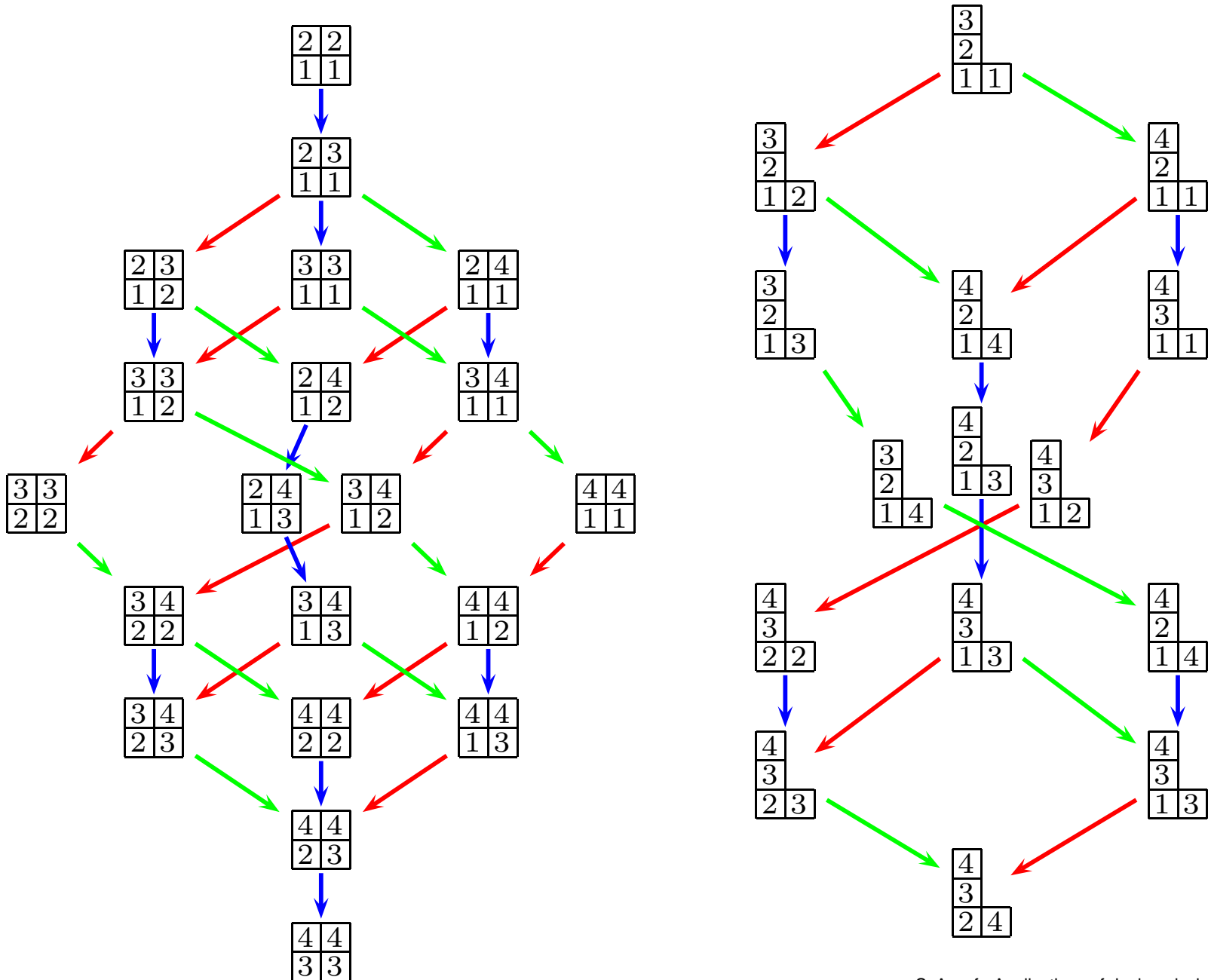

Local characterization of crystal graphs

Stembridge gave a **local characterization** for type A crystals:

- All monochromatic directed paths have finite length.
- For every x , there is at most one edge $x \xrightarrow{i} y$ (resp. $x \xleftarrow{i} z$).
- The j -string through x is either 1 shorter at the tail or 1 longer at the head than the j -string through $\tilde{e}_i(x)$.
- The following diagram shows how i -edges and j -edges interact:

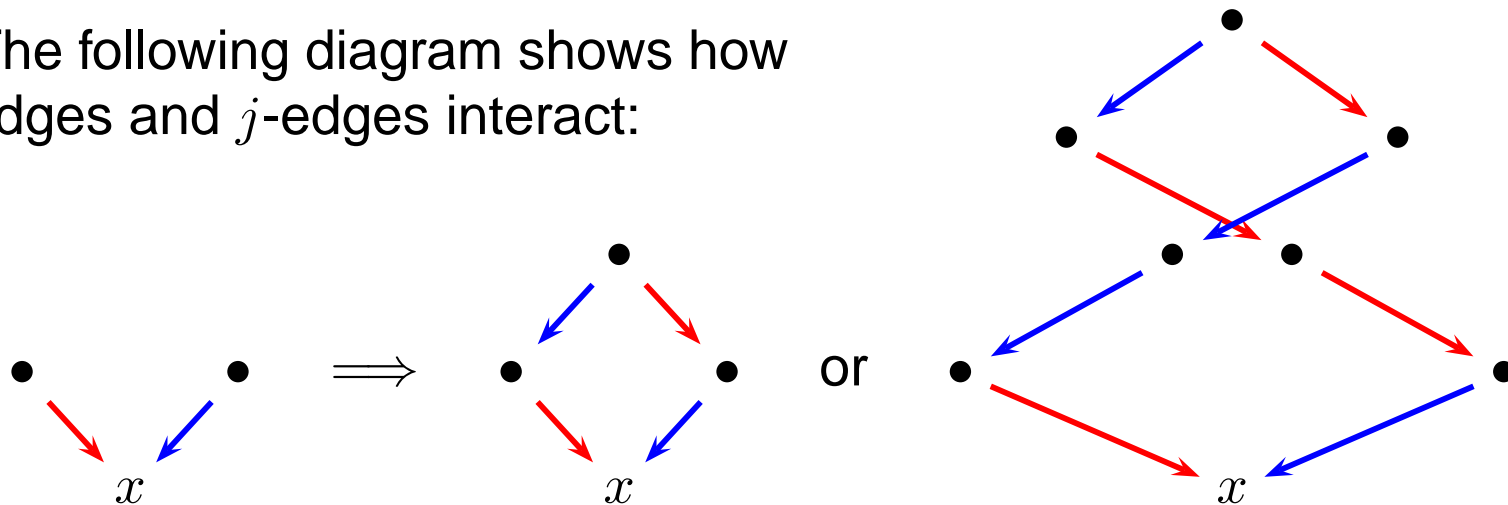

Theorem. (Stembridge 2003) The graph \mathcal{X}_λ^n satisfies the above axioms, and any connected component of a directed, colored graph satisfying the axioms is isomorphic to \mathcal{X}_λ^n for some λ, n .

Dual equivalence graphs

Motivated by crystal graphs, in 2005, Haiman suggested defining a graph on **standard** tableaux using the dual equivalence relation.

An **elementary dual equivalence** for $i-1, i, i+1$ is

$$\dots i \dots i \pm 1 \dots i \mp 1 \dots \equiv^* \dots i \mp 1 \dots i \pm 1 \dots i \dots$$

The graph \mathcal{G}_λ is the (vertex-signed) edge-colored graph on $\text{SYT}(\lambda)$ with an i -edge between two tableaux which differ by an elementary dual equivalence for $i-1, i, i+1$.

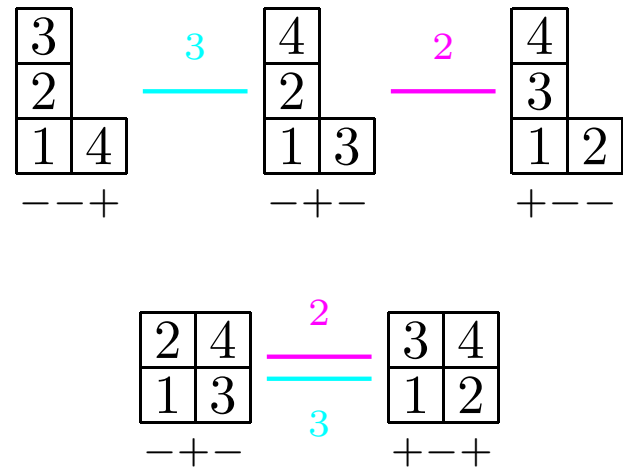

$$\text{Here } \sigma(T) \in \{\pm\}^{n-1} \text{ is given by } \sigma(T)_i = \begin{cases} + & \text{if } i \text{ left of } i+1 \text{ in } w_T \\ - & \text{if } i+1 \text{ left of } i \text{ in } w_T \end{cases}$$

Examples of DEGs

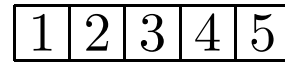

++++

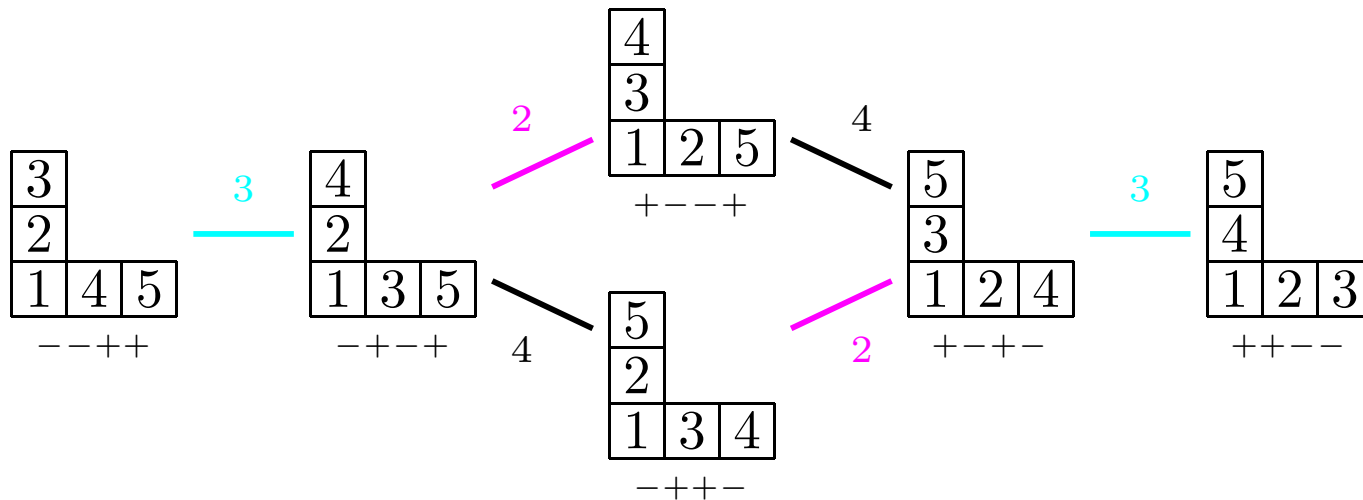
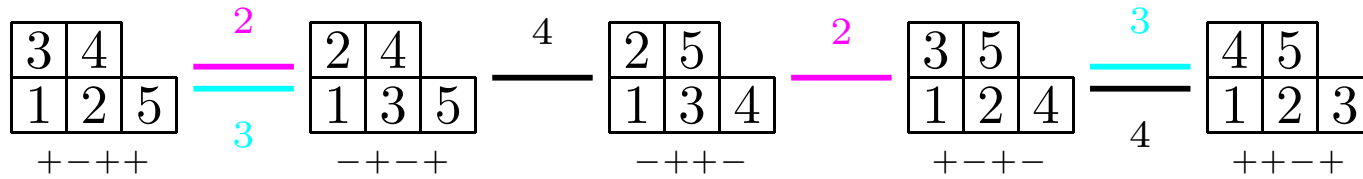
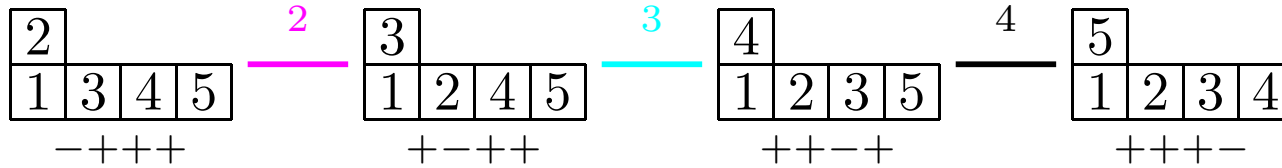

A local characterization for DEGs

Definition. (A. 2007) A *dual equivalence graph* (DEG) is a vertex-signed, edge-colored graph satisfying the following:

- across an i -edge, $\dots ? + - ? \dots \overset{i}{\text{---}} \dots ? - + ? \dots$
- if $\dots - + - \dots \overset{i}{\text{---}} \dots + - + \dots$, then $\bullet \overset{i}{\text{---}} \bullet$
 $\underset{i-1}{\text{---}}$
- For 3 consecutive edge colors, components of the graph are

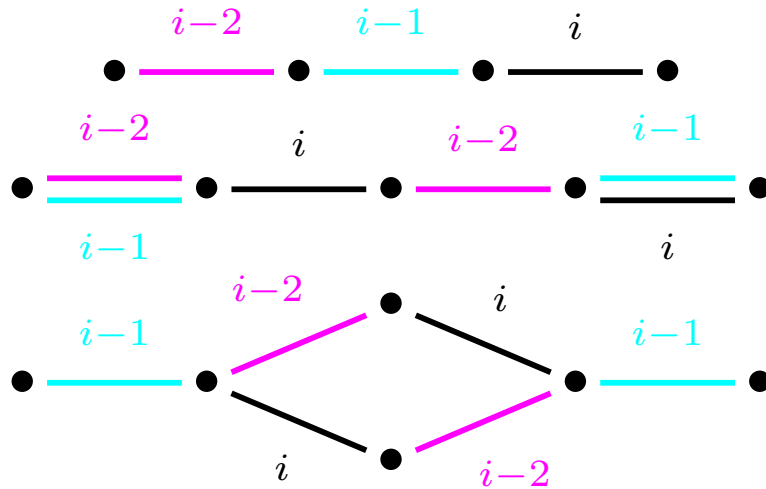

- For $|i - j| \geq 3$,

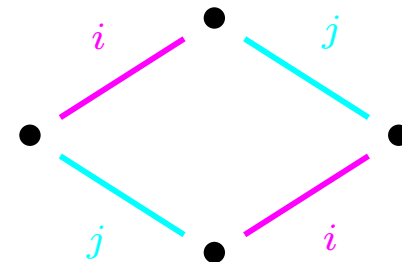

Theorem. (A. 2007) The graph \mathcal{G}_λ is a DEG and every connected component of a DEG is isomorphic to \mathcal{G}_λ for a unique partition λ .

II. Symmetric Functions

Schur positivity

Combinatorially, the **Schur function** s_λ may be defined by

$$s_\lambda(\mathbf{x}) = \sum_{T \in \text{SSYT}(\lambda)} \mathbf{x}^{\text{wt}(T)} = \sum_{T \in \text{SYT}(\lambda)} Q_{\sigma(T)}(\mathbf{x}).$$

Given a generating function for some set of (standard) objects,

$$\begin{array}{ccc} \sum_{S \in \text{objects}} q^{\text{stat}(S)} \mathbf{x}^{\text{wt}(S)} & = & \sum_{S \in \text{standard objects}} q^{\text{stat}(S)} Q_{\sigma(S)}(\mathbf{x}) \\ \downarrow & & \downarrow \\ \text{construct a crystal graph } \mathcal{X} \text{ on objects} & & \text{construct a DEG } \mathcal{G} \text{ on standard objects} \\ \downarrow & & \downarrow \\ \sum_{\lambda} \left(\sum_{\mathcal{C} \cong \mathcal{X}_\lambda^n} q^{\text{stat}(\mathcal{C})} \right) s_\lambda(\mathbf{x}) & & \sum_{\lambda} \left(\sum_{\mathcal{C} \cong \mathcal{G}_\lambda} q^{\text{stat}(\mathcal{C})} \right) s_\lambda(\mathbf{x}) \end{array}$$

where *stat* is *constant on connected components* of the graph.

LLT polynomials

In 1997, Lascoux, Leclerc and Thibon (LLT) defined $\tilde{G}_\mu^{(k)}$ to be the generating function for k -tuples of tableaux weighted by inv_k :

$$\tilde{G}_\mu^{(k)}(\mathbf{x}; q) = \sum_{\mathbf{T} \in \text{SSYT}_k(\mu)} q^{\text{inv}_k(\mathbf{T})} \mathbf{x}^{\text{wt}(\mathbf{T})} = \sum_{\mathbf{T} \in \text{SYT}_k(\mu)} q^{\text{inv}_k(\mathbf{T})} Q_{\sigma(\mathbf{T})}(\mathbf{x}).$$



In 2005, van Leeuwen (building on work of Carré-Leclerc) gave a **crystal-theoretic** proof for $k = 2$ taking approximately 50 pages.



A **DEG** structure is far simpler: use **dual equivalence** whenever this preserves inv_k , and otherwise does the only other “local” move.

A graph for LLT polynomials

The key to defining edges lies in the following involutions

$$\begin{array}{ccc} \dots i \dots i \pm 1 \dots i \mp 1 \dots & \xleftrightarrow{d_i} & \dots i \mp 1 \dots i \pm 1 \dots i \dots \\ \dots i \dots i \pm 1 \dots i \mp 1 \dots & \xleftrightarrow{\tilde{d}_i} & \dots i \pm 1 \dots i \mp 1 \dots i \dots \end{array}$$

There is a notion of the *distance* between two entries:

$$\begin{array}{l} \text{dist}(i, j) < k \iff i, j \text{ form a potential } k\text{-inversion} \\ \text{dist}(i, j) = k \iff i, j \text{ appear in the same tableau as } \begin{array}{|c|} \hline i \\ \hline j \\ \hline \end{array} \text{ or } \begin{array}{|c|} \hline j \\ \hline i \\ \hline \end{array} \end{array}$$

$$\text{Define an involution } D_i^{(k)}(\mathbf{T}) = \begin{cases} d_i(\mathbf{T}) & \text{if } \text{dist}(i-1, i, i+1) > k \\ \tilde{d}_i(\mathbf{T}) & \text{if } \text{dist}(i-1, i, i+1) \leq k \end{cases}$$

Fact: $\text{inv}_k(\mathbf{T}) = \text{inv}_k(D_i^{(k)}(\mathbf{T}))$. Therefore define $\mathbf{T} \xrightarrow{i} D_i^{(k)}(\mathbf{T})$.

It is straightforward to check that this defines a **DEG D graph**.

The generating function of a **D graph** is Schur positive, and so ...

Theorem. (A. 2007) The LLT polynomial $\tilde{G}_\mu^{(k)}$ is Schur positive.

From D graphs to DEGs

D graphs: vertices of conn comps of $D_{i-2} \cup D_{i-1} \cup D_i$ are in bijection with $\text{SYT}(\lambda^1) \cup \dots \cup \text{SYT}(\lambda^m)$.

DEGs: vertices of conn comps of $D_{i-2} \cup D_{i-1} \cup D_i$ are in bijection with $\text{SYT}(\lambda)$.

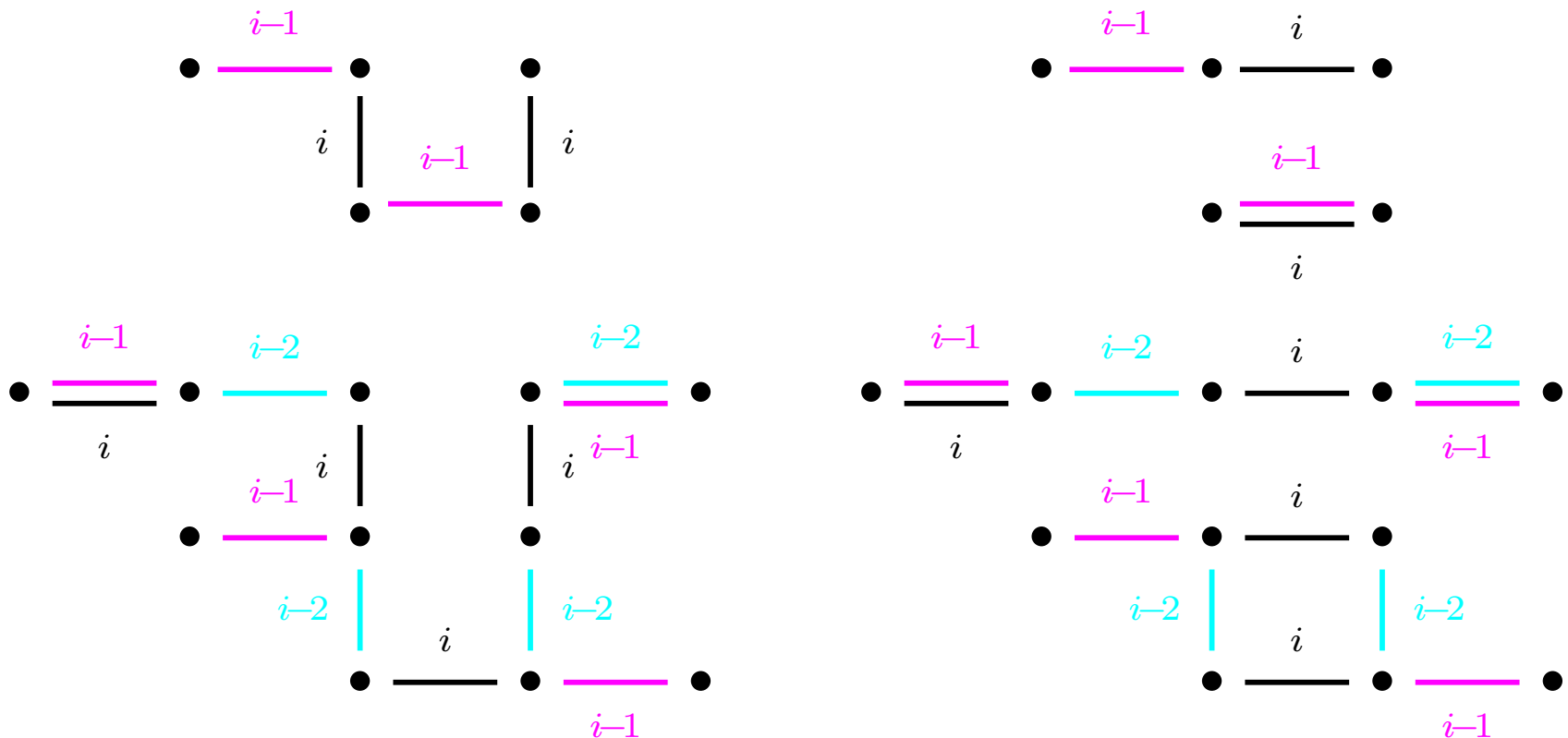

Theorem. (A. 2007) A **D graph** may be transformed into a **DEG** in such a way that preserves the generating function.

Macdonald positivity

Macdonald polynomials, defined by Macdonald in 1988, may be expressed as the generating function for **fillings of a partition diagram** (conjectured by Haglund, proved by Haglund-Haiman-Loehr 2005):

$$\tilde{H}_\mu(\mathbf{x}; q, t) = \sum_{S: \mu \rightarrow \mathbb{Z}_+} q^{\text{inv}(S)} t^{\text{maj}(S)} \mathbf{x}^{\text{wt}(S)} = \sum_{S: \mu \xrightarrow{\sim} [n]} q^{\text{inv}(S)} t^{\text{maj}(S)} Q_{\sigma(S)}(\mathbf{x}).$$

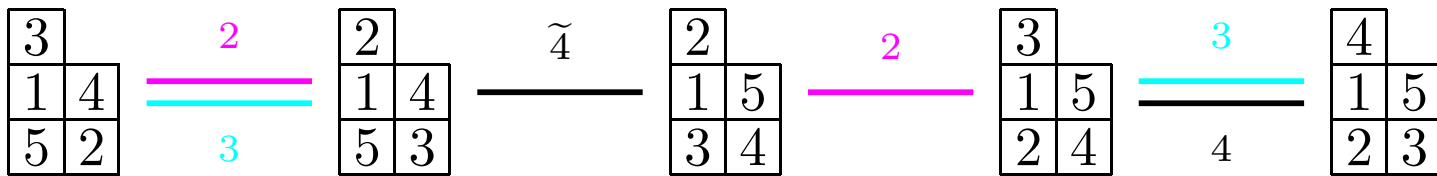

Construct a **D graph** on fillings using the following involution:

$$D_i(S) = \begin{cases} \tilde{d}_i(S) & \text{if } i-1, i, i+1 \text{ fit in } \begin{array}{|c|c|c|} \hline & \dots & \\ \hline & & \\ \hline \end{array} \\ d_i(S) & \text{otherwise.} \end{cases}$$

Theorem. (A. 2007) The Macdonald polynomial \tilde{H}_μ is Schur positive.

III. Representation Theory

Weyl groups acting on 0-weight spaces

G = complex, reductive Lie group W = Weyl group of G
 E = finite dim. irrep. of G over \mathbb{C} E^0 = 0-weight space of E

Goal: Determine how the natural action $W \curvearrowright E^0$ decomposes.

Example (studied by Gutkin in 1973):

Let $G = \mathrm{SL}_n$, $W \cong \mathcal{S}_n$, and E = an irreducible component of $(\mathbb{C}^n)^{\otimes n}$, then E^0 is an irrep of \mathcal{S}_n and all irreps of \mathcal{S}_n arise in this way.

More generally...

Let E_λ be the irrep of SL_n with highest weight $\lambda = (\lambda_1, \dots, \lambda_n)$.

Then E_λ^0 is nontrivial if and only if $\lambda_1 + \dots + \lambda_n = kn$ for some $k \in \mathbb{Z}_+$.

When this is the case, E_λ^0 consists of all vectors of weight (k, \dots, k) .

Goal: Decompose $\mathcal{S}_n \curvearrowright E_\lambda^0$ into irreps of \mathcal{S}_n .

A motivating example

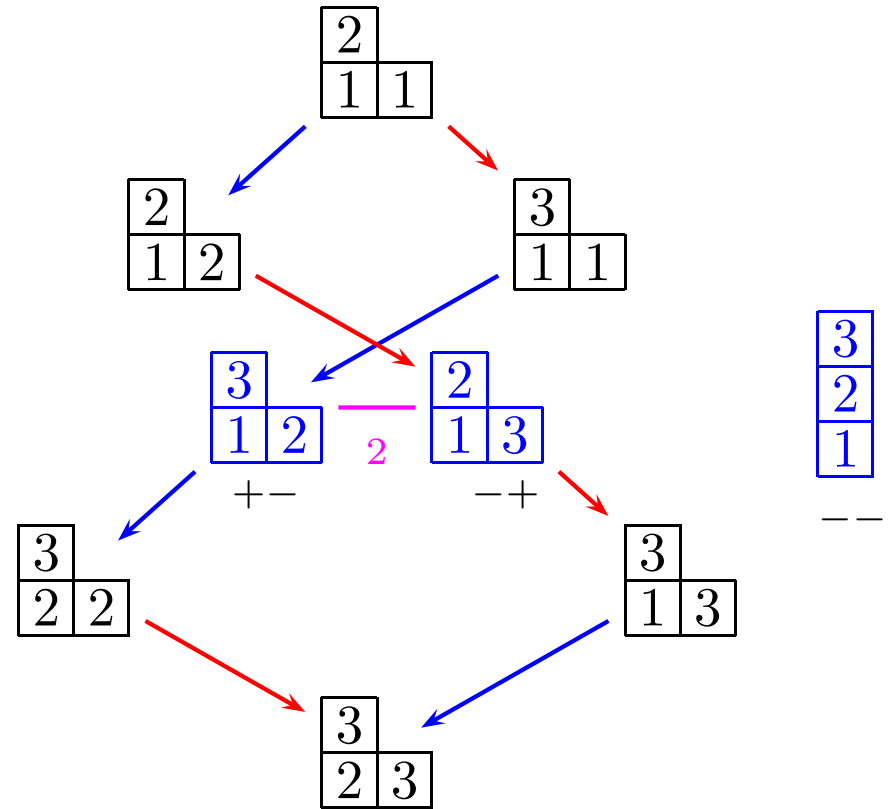
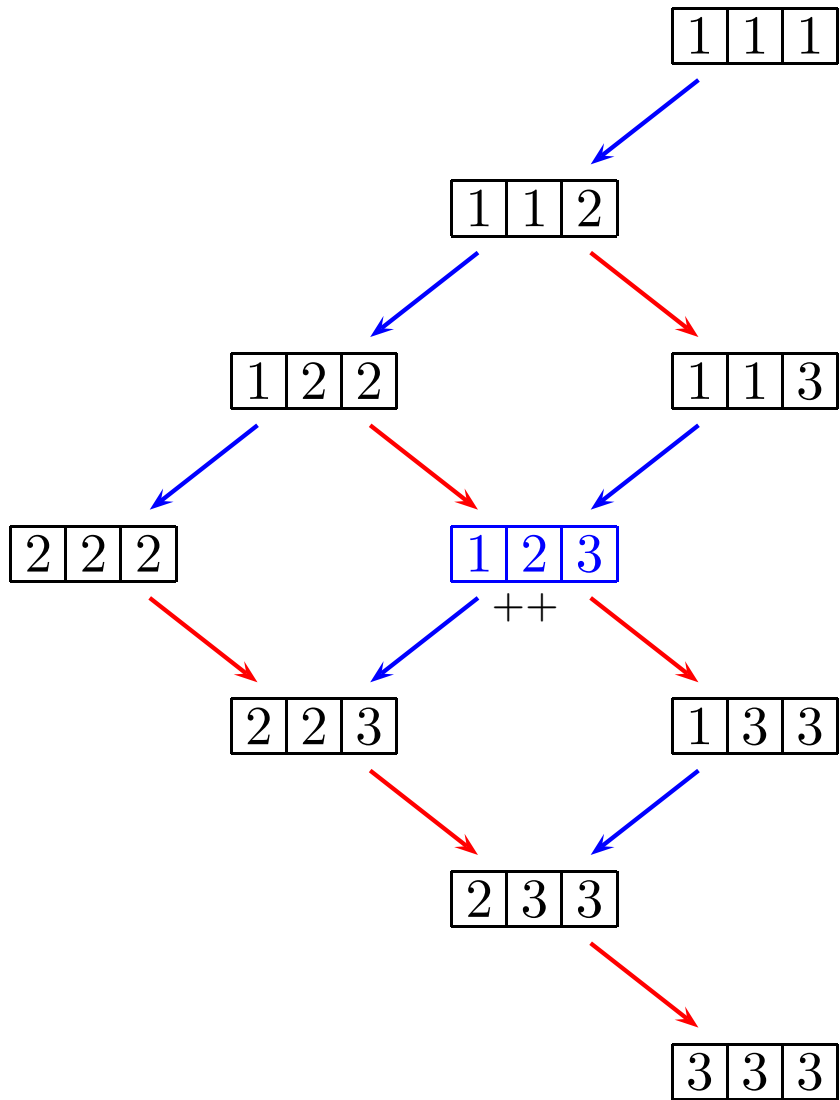

From crystals to DEGs

Combinatorially, the **0-weight space** of a **crystal graph** consists of all vertices which lie at the center of each i -string.

Given a crystal graph \mathcal{X} , define a vertex-signed, edge-colored graph $\mathcal{G}(\mathcal{X}) = (V, \sigma, D)$ as follows:

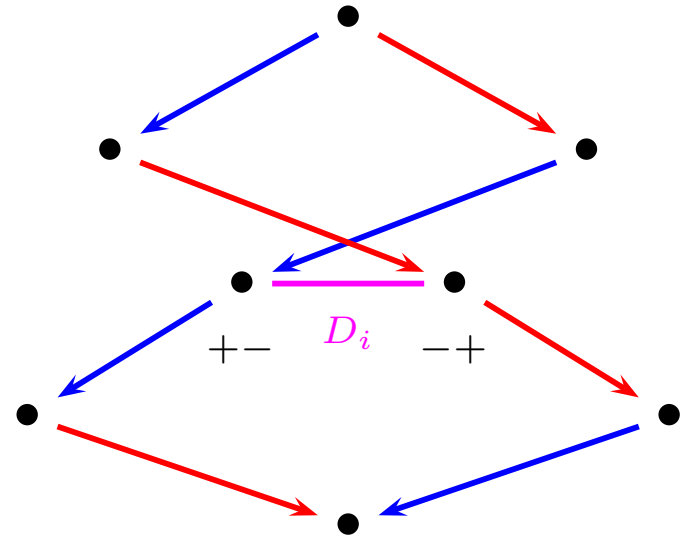

$$V = \{x \in \mathcal{X} \mid \varepsilon(x, i) = -\delta(x, i) = 0 \text{ or } 1 \quad \forall i, \}$$

$$\sigma(x)_i = \begin{cases} + & \text{if } \varepsilon(x, i) = 1 \\ - & \text{if } \varepsilon(x, i) = 0 \end{cases}$$

$$D_i(x) = \begin{cases} \tilde{f}_{i-1} \tilde{f}_i \tilde{e}_{i-1} \tilde{e}_i x & \text{if } \varepsilon(x, i) = 1 \text{ and } \varepsilon(x, i-1) = 0 \\ \tilde{f}_i \tilde{f}_{i-1} \tilde{e}_i \tilde{e}_{i-1} x & \text{if } \varepsilon(x, i) = 0 \text{ and } \varepsilon(x, i-1) = 1 \end{cases}$$

Examples of the construction of $\mathcal{G}(\mathcal{X})$

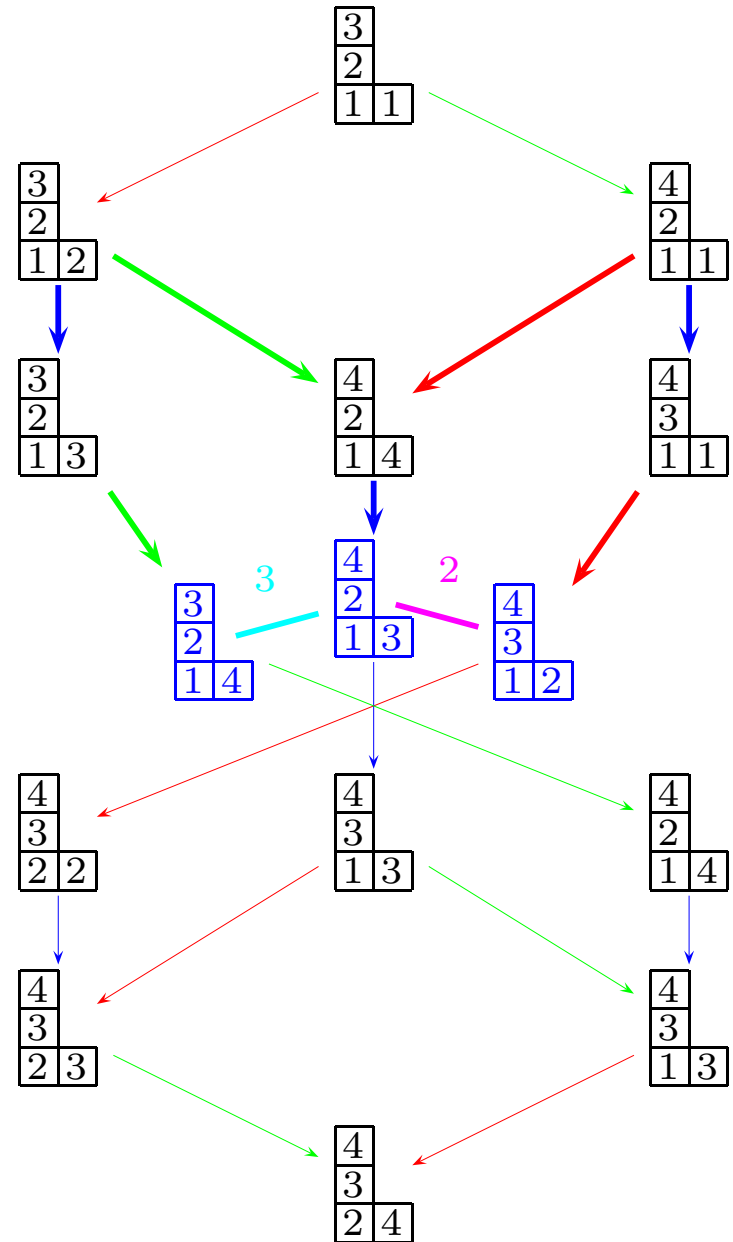
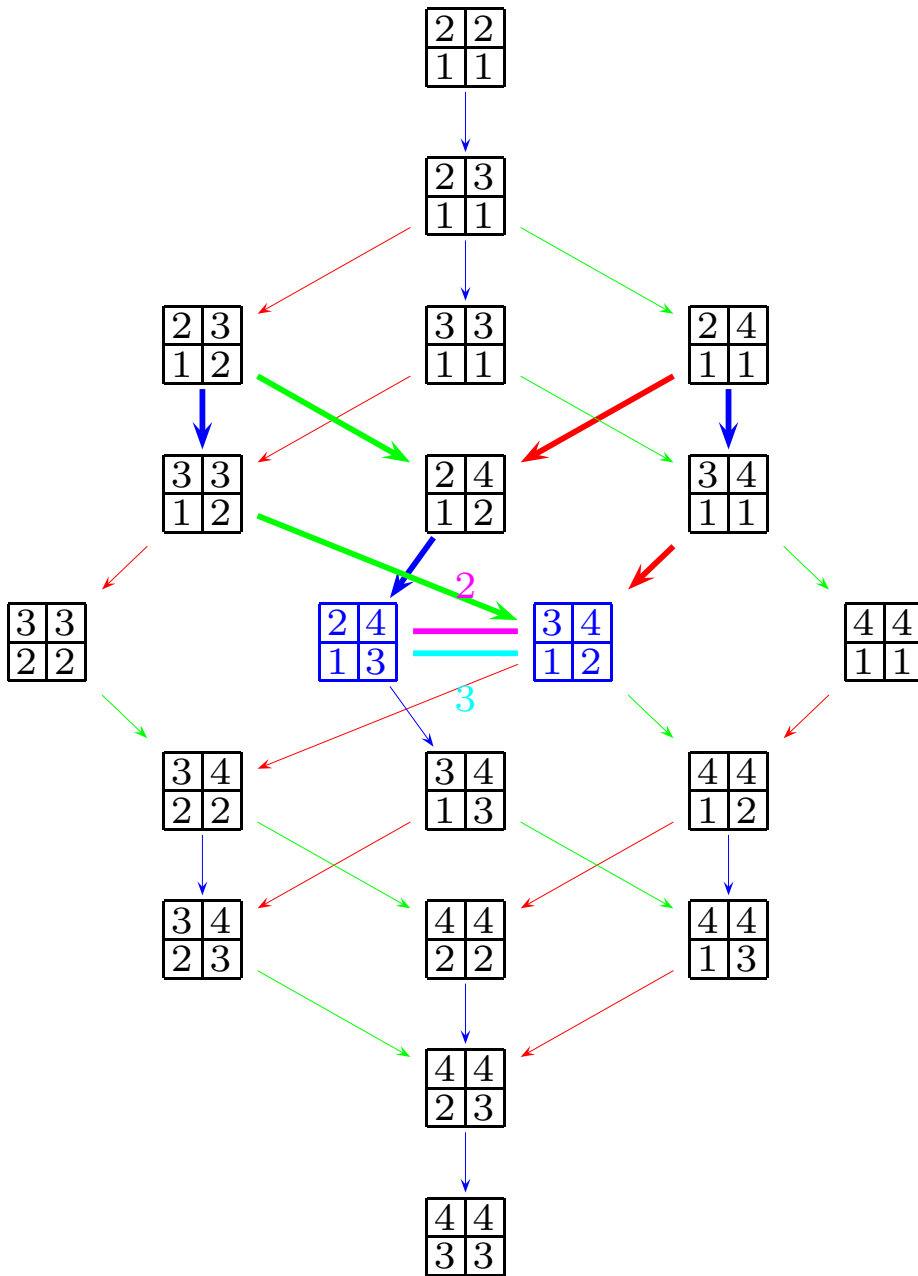

Combinatorial Schur-Weyl duality

It follows from the **local characterization** for crystal graphs (Stembridge) that if \mathcal{X} is a crystal graph, the $\mathcal{G}(\mathcal{X})$ is well-defined.

Using the **local characterizations** for crystal graphs and for dual equivalence graphs, we have the following result.

Theorem. (A. 2007) If \mathcal{X} is a crystal graph with 0-weight space given by V , then $\mathcal{G}(\mathcal{X})$ is a dual equivalence graph.

Corollary. Let $\lambda = (\mu_1 + m, \mu_2 + m, \dots, \mu_n + m)$ for some partition μ of n and some integer $m > 0$. Then $\mathcal{G}(\mathcal{X}_\lambda^n) = \mathcal{G}_\mu$.

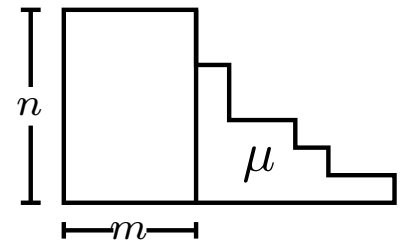

For GL_n , we need to modify the signatures based on the parity of m :

$$\sigma(x)_i = \begin{cases} + & \text{if } \varepsilon(x, i) + m \text{ is even} \\ - & \text{if } \varepsilon(x, i) + m \text{ is odd} \end{cases} \rightsquigarrow \mathcal{G}(\mathcal{X}_\lambda^n) = \begin{cases} \mathcal{G}_\mu & \text{for } m \text{ even} \\ \mathcal{G}_{\mu'} & \text{for } m \text{ odd} \end{cases}$$

In general, V consists of all vertices of \mathcal{X} at the center of each i -string.

Let E be the irrep of SL_4 with highest weight $\lambda = (4, 3, 1, 0)$.

$$V = \left\{ \begin{array}{c} \begin{array}{|c|} \hline 4 \\ \hline \end{array} \\ \begin{array}{|c|c|c|} \hline 2 & 3 & 3 \\ \hline \end{array} \\ \begin{array}{|c|c|c|c|} \hline 1 & 1 & 2 & 4 \\ \hline \end{array} \end{array} \right. \left\{ \begin{array}{c} \begin{array}{|c|c|c|} \hline 4 & & \\ \hline 3 & 3 & 4 \\ \hline 1 & 1 & 2 & 2 \end{array} \\ \begin{array}{|c|c|c|} \hline 4 & & \\ \hline 2 & 3 & 4 \\ \hline 1 & 1 & 2 & 3 \end{array} \end{array} \right. \left\{ \begin{array}{c} \begin{array}{|c|c|c|} \hline 4 & & \\ \hline 2 & 2 & 4 \\ \hline 1 & 1 & 3 & 3 \end{array} \\ \begin{array}{|c|c|c|} \hline 3 & & \\ \hline 2 & 4 & 4 \\ \hline 1 & 1 & 2 & 3 \end{array} \end{array} \right. \left\{ \begin{array}{c} \begin{array}{|c|c|c|c|} \hline 3 & & & \\ \hline 2 & 3 & 4 & \\ \hline 1 & 1 & 2 & 4 \end{array} \\ \begin{array}{|c|c|c|} \hline 3 & & \\ \hline 2 & 2 & 4 \\ \hline 1 & 1 & 3 & 4 \end{array} \end{array} \right.$$

The decomposition into irreps of S_4 is $E^0 \cong S^{1,1,1,1} \oplus S^{2,1,1} \oplus S^{3,1}$.

The edges of $\mathcal{G}(\mathcal{X})$ are not determined solely by $\tilde{e}_{i-1}, \tilde{f}_{i-1}, \tilde{e}_i, \tilde{f}_i$.
The edges cannot be defined by restriction and *jeu de taquin*.

A rule for edges of $\mathcal{G}(\mathcal{X})$ has been worked out in several cases (sometimes giving a **D graph**), but the general rule is still a mystery.